



Code Officer
Shannon Darker
c/o ARRO Consulting, Inc.
1-570-366-9534

Orwigsburg Borough
Curb, Sidewalk and Driveway Permit Application
Schuylkill County, Pennsylvania

Mail Applications to:
ARRO Consulting, Inc.
1239 Centre Turnpike
Orwigsburg, Pa. 17961

1. PROPERTY OWNER INFORMATION

Owner(s) Name:		
Site Location of Property (Full Address):		
Tax Map Parcel ID#	Phone:	Email:

2. DESCRIPTION OF WORK

Provide detailed description of proposed work (curb, sidewalk, or driveway):

Length:	Width:	Type:
Contractor:	Address:	Phone #:
		Email:

3. PROPERTY PLAN AND CONSTRUCTION DETAILS

- Attached is a dimensioned plan of the proposed work and parcel indicating north, property lines, streets, easements, right-of ways, proposed work area and construction details.
- A Pennsylvania One-Call has been made (1-800-242-1776 three days before digging). The One-Call Serial Number is _____ . Construction MUST NOT begin until received.

4. APPLICANT INFORMATION

Applicant:	Address:	Phone #:
		Email:

I, the undersigned, do hereby certify that the information contained in this application is true and correct and that the proposed work, as outlined will conform to the standards of the Orwigsburg Borough Curb, Sidewalk and Driveway Ordinance and Standard Details and all other applicable Borough Ordinances/regulations. Fees are to be made payable to: **BOROUGH OF ORWIGSBURG**. Furthermore, I do hereby understand that all work permitted by this application is required to be inspected by Orwigsburg Borough or their agent at intervals as outlined by the Orwigsburg Borough Curb, Sidewalk and Driveway Permit and Inspection Fee Schedule.

Print Name: _____ Signature: _____ Date: _____

5. REVIEW, APPROVALS AND INSPECTIONS (BOROUGH USE ONLY)

Application is hereby Permit for: Curb Sidewalk Driveway Approved Denied Incomplete Standard Alternative

Remarks: _____

By: _____ DATE: _____

Application Fee: _____ Inspection Fee: _____ TOTAL FEE PAID: _____

Check No.: _____ Cash PERMIT# _____

INSPECTED ON: _____ BY: _____ WORK INSPECTED: _____

RESOLUTION No. 2010-11
ORWIGSBURG BOROUGH CURB, SIDEWALK and DRIVEWAY PERMIT
AND INSPECTION FEE SCHEDULE

Permit Application Fee:

New and Replacement Curbs, Sidewalks and Driveway Aprons	\$50.00
Replacement of Curb sections less than 20' in length, Sidewalk section 50 square feet or less or driveway aprons servicing existing driveways	\$25.00
Alternative, Curbs, Sidewalks and Driveway Aprons	\$75.00

Inspection Fees:

Curbs

Along existing paved roads (Up to 300 L.F.)	\$100.00
Additional per each 300 L.F. or portion thereof	\$50.00
Along unpaved road (New Development)	\$100.00
(Per 500 L.F. or portion thereof)	\$70.00
New depressed Curb for Driveway	\$70.00

Note: Where a combination of standard curbs and depressed curbs are proposed for the same project (formed and poured in continuous segment), only the curb inspection fee shall apply.

Sidewalks and Driveway Aprons

New or replacement of existing sidewalks and driveway aprons (Up to 300 L.F.)	\$70.00
Additional per each 300 L.F. or portion thereof	\$25.00

Alternative Curbs, Sidewalks or Driveway Aprons

Inspection fees shall be based on the alternative proposed. An estimated inspection fee shall be prepared by the code enforcement officer and approved by Orwigsburg Borough Council and submitted in writing to the applicant prior to submission of the request for use of alternative materials to the Orwigsburg Borough Council.

Note: Where a combination of curbs, sidewalks and driveway aprons are proposed for the same project (planting strip between curb and sidewalk and curbs/sidewalk formed simultaneously), 100 percent of the curb inspection fee and 75 percent of the sidewalk inspection fee and 75% of the driveway inspection fee shall apply.

Establish Grade by Borough Engineer - to be determined based on the extent of the work.

Inspection requirements

Curbs

Along existing road (1 Inspection Required)

1. Curbs shall be inspected following compaction of subgrade, placement of stone base and forms and immediately prior to pouring concrete.

Along unpaved road (1 Inspection required)

1. Curbs shall be inspected following compacting of subgrade, placement of stone base and forms and immediately prior to pouring concrete and during pavement replacement.

Sidewalks and Driveway Aprons (1 Inspection required)

1. All sidewalks and driveways shall be inspected following to placement of stone base and forms but immediately prior to pouring concrete.

Alternative Curbs, Sidewalks and Driveway Aprons

Inspection requirements to be established dependent upon proposed alternative.

Note: Curb, sidewalk and driveway apron segments poured on separate days shall constitute individual inspection fees per segment. Any additional inspections as may be required due to poor construction and subsequent replacement will be billed on an hourly rate of \$100/hr.

Adopted at the regular meeting of the Borough Council of the Borough Council of the Borough of Orwigsburg this 14th day of April 2010.

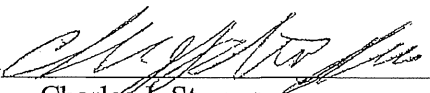
Approved 
Charles J. Sterner
Council President

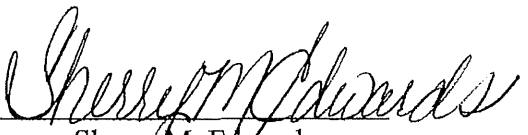
Attest 
Sherry M. Edwards
Borough Secretary

ORDINANCE NO. 398

AN ORDINANCE OF THE BOROUGH OF ORWIGSBURG, SCHUYLKILL COUNTY, PENNSYLVANIA, REGULATING THE GRADING OF NEW SIDEWALK AREAS AND THE CONSTRUCTION AND REPAIR OF CURBS, SIDEWALKS, DRIVEWAY ENTRANCES AND NEW STREETS, AND REQUIRING PERMITS THEREFOR; REQUIRING THE PLACEMENTS OF SIGNS, BARRIERS AND LIGHTS; PROVIDING FOR INDEMNIFICATION OF THE BOROUGH FOR LIABILITY; PROVIDING PENALTIES AND REMEDIES FOR VIOLATION THEREOF; PROVIDING FOR REPEAL OF CERTAIN ORDINANCES.

Be it enacted and ordained by the Council of the Borough of Orwigsburg that from and after the passing hereof:

SECTION 1. Grading of sidewalk areas and construction and repair of sidewalks, curbs, driveway entrances and new streets and permits therefor:

- (a) No person, firm, or corporation shall grade any sidewalk area, construct, reconstruct, repair or replace any sidewalk, curb, driveway entrance, or new street within the Borough of Orwigsburg except in compliance with the provisions of this Ordinance, and in the case of new streets, curbs and sidewalks to be constructed within a subdivision as approved by Borough Council and duly recorded, compliance with all provisions of the Orwigsburg Borough Subdivision and Land Development Ordinance. If this Ordinance or other Borough Ordinance conflicts in requirements, specifications, etc., the more restrictive requirement or specification shall apply.
- (b) The grading of sidewalk areas, the construction and repair of sidewalks, curbs, driveway entrances and new streets shall be performed or caused to be performed by the owner or owners of the lot or lots abutting thereon in accordance with the lines and grades established by Ordinance or as directed by the Borough Engineer or Code Enforcement Officer in accordance with the provisions of this Ordinance.
- (c) Any person, firm, or corporation desiring to grade or excavate any sidewalk or curb area, or desiring to construct, reconstruct, repair or replace any sidewalk, curb, driveway entrance or new street shall first obtain a permit therefor from the Borough Code Enforcement Officer who shall

issue a permit only if and after the following conditions have been satisfied: (1) the filing of a written application with said Borough Code Enforcement Officer upon such form as is approved by the Borough Council, setting forth the location, purpose, materials, and detailed description of the improvement; (2) the approval by the Borough Engineer, if required by the Code Enforcement Officer, of the said application; (3) the payment of a permit fee and inspection fee as established by the Orwigsburg Borough Council, by resolution, payable to the Borough of Orwigsburg at the time of filing application, which fee shall be the total fee regardless of the number of improvements set forth in the application.

- (d) A permit issued pursuant to the terms of this Ordinance shall be effective for a period of ninety (90) days from the date of issuance and may, prior to expiration of the original, be renewed by the Borough Code Enforcement Officer for a period of ninety (90) days upon application and payment of one-half of the original Permit and Inspection Fee. Permits may not be renewed for more than one renewal period of ninety (90) days. The Borough Code Enforcement Officer shall close an active permit upon final inspection of and approval of improvements outlined in the application. A permit must be renewed if final approval of all work covered under the approved permit is not obtained within the ninety (90) day period.
- (e) In the case of any improvement regulated by this Ordinance, the Engineer, when requested by the applicant, shall furnish applicant with necessary lines and/or grades if available, the cost of which shall be paid for by the applicant. In the case where the information is not available, the applicant may hire the Borough Engineer to establish the line /grade or the applicant may engage another consultant to provide that information to the Borough engineer for review. Where there are existing curbs, permits shall be granted only after inspection by the Borough Code Enforcement Officer or the Borough Engineer and a deposit in the amount established by resolution by the Orwigsburg Borough Council is submitted, payable to the Borough of Orwigsburg. If such service is requested or is required alone, the original permit must be signed and dated by the

Borough representatives approving grades, lines, etc. In the case where the applicant does not request confirmation of grades or lines and the curb, sidewalk, or driveway is deemed deficient by the Borough, Borough Engineer or Code Enforcement Officer, the curb, sidewalk, or driveway shall be replaced to the satisfaction of the Borough at the owner's expense.

- (f) Before a proposed driveway will be accepted by the Borough Council, said plans and specifications for said proposed driveway in a form satisfactory to the Borough Engineer must be submitted and approved by the Borough Council, setting forth that the base of said driveway within the Borough right-of-way shall be not less than six (6") inches of approved sub-base material (2A stone), plus one and one-half (1 ½") inches of bituminous binder course and one inch (1") of bituminous paving or 25 mm Superpave. Concrete driveways within the Borough right-of-way shall be constructed to a depth of six (6") inches of 2A stone and six (6") inches of concrete.
- (g) All new, repaired or replaced sidewalk areas shall be graded and all new, repaired or replaced sidewalks, curbs, driveway entrances shall be constructed, reconstructed or repaired in conformity with the specifications attached as part of this ordinance. In instances where the replacement of curbs and sidewalks includes ramps and curb cuts in accordance with the American's with Disabilities Act, these must conform to the guidelines outlined in the Pennsylvania Department of Transportation Publication 72M, and the American with Disabilities Act, as amended. These details can be found at: ftp://ftp.dot.state.pa.us/public/Bureaus/design/PUB72M/RC-67M_c3.pdf
- (1) The owner, his agents or employees shall perform the necessary excavation and grading. All fills shall be made with clean fill consisting of earth or rock to the depth of the excavation required for the proposed improvement. All subgrade excavations shall be well tamped. 2B stone shall be placed to a depth of four (4") inches for sidewalks, driveways, and curbs and well tamped.

- (2) All new or replaced sidewalk and curbing shall be constructed of concrete, excepting sidewalks approved under Section I. (h) of this ordinance. Concrete may be ready-mix or transit-mix. The cement shall be a brand of American Portland approved by the Borough Engineer. The sand shall be clean and sharp and contain no earth. The stone shall be clean, hard, and free from loam. All materials, testing and workmanship must conform to Pennsylvania Department of Transportation Publication 408. Concrete shall be rated with a minimum of Three Thousand Five Hundred (3,500) Pounds per Square Inch compressive strength rated.
- (3) All curbs and sidewalks shall be individually placed. Monolithic pouring of curbs and sidewalks is prohibited. The gentle tamping of large particles below the top surface is recommended. Curbs, sidewalks, and driveways shall not be finished with a smooth surface. The surface texture must provide some degree of slip resistance. Any small quantity of mortar that may be required for the finishing shall be applied while the concrete is wet and only enough to smooth the surface.
- (4) The curbing and sidewalk shall have joints spaced as shown on the Borough of Orwigsburg Standard Detail Plan . One-half inch expansion joints shall be placed at all vertical components, signs, stairways, porches, etc., in order to facilitate removal and/or replacement of the component. At a minimum, bituminous expansion joints shall be placed at property lines or every twenty (20') feet maximum with relief joint spacing as shown on the Borough of Orwigsburg Standard Detail.
- (5) In the case of sidewalks that are being repaired or replaced, a thirty (30") inch square box shall be placed around all traffic control signs (stop signs, street signs, etc.), and a two (2') foot square box around all poles (electric, telephone, cable television, etc.), a three (3') foot square box shall be placed around all existing and proposed trees to provide unrestricted growth, provided the minimum sidewalk width of sixty (60 ") inches can be maintained in

all instances. In cases where the above dimensions cannot be provided due to site conditions, the Orwigsburg Code Enforcement Officer may, at his/her discretion, approve a lesser area.

This approval must be provided in writing prior to starting the work.

- (6) Private driveways shall be constructed as a unit as shown on the Borough of Orwigsburg Standard Details. .
 - (7) All curbing and sidewalk radii and locations shall conform to the Orwigsburg Borough Subdivision and Land Development Ordinance and Orwigsburg Borough Zoning Ordinance.
 - (8) ADA accessible curb ramps are required at all intersections and shall conform to Pennsylvania Department of Transportation specifications.
 - (9) A one (1') foot cut-back at all street lines shall be saw cut, excavated and replaced with six (6") inches 2A stone, four (4") inches bituminous concrete base coarse plus one and one-half (1 ½") inches I.D.2 bituminous wearing or 9.5 mm Superpave. AET tack shall be placed on all exposed vertical edges, PG64-22 shall be placed on horizontal seams per Pennsylvania Department of Transportation specifications.
 - (10) Capping of damaged curbs is prohibited. The entire depth of all deteriorated curbs must be replaced with a minimum length of curb to be replaced being no less than five (5') feet in length. Sidewalks may be replaced in sections, a minimum length or portion being that of the required expansion or relief joint spacing that is existing or as designated by this Ordinance and the Borough of Orwigsburg Standard Specifications
- (h) The proposed construction, reconstruction or replacement of sidewalks, curbing, and driveway entrances with alternative materials and installation other than concrete as specified in Section I. shall be subject to the following:
- (1) The property owner shall present all requests for the use of alternative materials and/or installations to the Code Enforcement Officer in writing.

- (2) All applications received shall be accompanied by four copies of the manufacturer's specifications, a color sample, detailed description of the installation method pursuant to the manufacturer's recommendations, drawing of the proposed pattern, and all other information required by the permit application.
- (3) The Code Enforcement Officer, upon receipt of all required information, shall forward one copy to Borough Council, one copy to the Borough Engineer.
- (4) The Borough Engineer and Borough Code Enforcement Officer shall present their recommendations to Borough Council within fourteen (14) days of receipt of the request. Borough Council, at its discretion may forward the request to the Borough's Planning Commission for review and comment.
- (5) Borough Council shall, at their next regularly scheduled meeting following the review period by the Engineer, and Code Enforcement Officer, and Planning Commission (as required) provide the applicant with approval, recommendations or denial for the requested use of alternative materials or installations.
- (6) The following minimum requirements shall apply to applications for alternative materials and installations:
 - (a) Color – The color of alternative materials shall be a single or combination of earth tone shades.
 - (b) Installation – Installation shall be conducted pursuant to the manufacturer's recommendations and not pose a public hazard.
 - (c) Materials – All proposed alternative materials shall be manufactured for the specific use.

(d) Patterns – All patterns of alternative materials and installations shall be consistent with the manufacturer’s recommendations and not be arranged to produce numerals or alphabetic letters or graphics of any nature.

- (i) On neglect or refusal of the owner or owners to construct or set any curb or driveway entrance, or to repair or reset any curb, sidewalk, or driveway entrance, within thirty (30) days after written notice to do so from the Council of said Borough through its proper officials, said Council may cause the same to be done and shall collect from said owner or owners of the lot or lots the cost thereof, and twenty-five (25%) percent additional, together with all charges and expenses, and if payment is not made, may file a municipal lien therefor against such lot or lots or shall bring a civil action against said owner or owners for collection thereof.
- (j) Sidewalk areas not graded, or sidewalks, curbs, and driveway entrances not laid in conformity with the provisions of this Ordinance and with established grades and that do not conform to the generally accepted standards of the American Concrete Institute, or any sidewalk, curb, or driveway entrance laid with material or materials not permitted by this Ordinance or in the opinion of Borough Council and the Borough Engineer are dangerous or in a deteriorated condition, shall be removed and regraded and/or re-laid according to the provisions of this Ordinance within a reasonable amount of time, not to exceed One Hundred Twenty (120) days after notice to the owners to do so by Council, through its proper officials. Upon neglect or failure of said owner or owners thereof to repair said sidewalk, curb or driveway entrance within the time stipulated, Council may cause the work to be done at the property owner’s cost and expense. The Council may collect the amount due plus twenty-five (25%) percent together with all charges, interest and expenses from the property owner. Where the amount remains unpaid for more than thirty (30) calendar days after written notice for payment has been given to the property owner, Council may file a municipal lien against the lot or lots.

SECTION 2. Placement of signs, barriers and lights:

- (a) Any person, firm, or corporation grading any sidewalk areas, constructing, reconstructing, paving, repaving, replacing, or repairing any curbs, sidewalks or driveway entrances, or removing any trees or shrubbery, or opening or excavating in or under any streets, alleys or sidewalk areas, or storing or depositing materials on any street, alley, or sidewalk area, shall place suitable temporary signs, barriers, and/or lights to protect the users of streets, alleys, or sidewalk areas in the improvement's vicinity from injury to person or property.
- (b) The Borough Engineer or Code Enforcement Officer may direct the person, firm or corporation doing the work to place a certain type and/or quantity of signs, barriers, or lights in a certain manner. If the work is being done in or along any State Highway, a Highway Occupancy Permit shall be obtained from the Pennsylvania Department of Transportation (PennDOT) prior to the start of any construction, reconstruction, paving, repaving, repairing, or replacing. All PennDOT regulations shall be followed regarding traffic control devices while construction, reconstruction, paving, repaving, repairing, or replacing is being done in or along any State Highway.
- (c) All traffic signs removed during construction, reconstruction, paving, repaving, repairing, or replacing of any curb, sidewalk, or driveway entrance shall be replaced by the person, firm, or corporation performing the installation pursuant to Section 1 of this Ordinance at his/her sole expense and in conformity with the directions of the Borough Engineer.
- (d) When traffic is maintained during construction, reconstruction, paving, repaving, repairing, or replacing of any curb, sidewalk, or driveway entrance, traffic control must be conducted by the person, firm, or corporation or by contractor of same pursuant to Manual on Uniform Traffic Control Devices (MUTCD) PADOT Publications 212 and 213 .

SECTION 3. Indemnification of the Borough:

Any person, firm, or corporation applying for any permit under this Ordinance shall indemnify and hold the Borough of Orwigsburg, the Borough Engineer and the Borough Code Enforcement Officer harmless against all claims, demands, actions, judgments or liability of whatever nature arising during the performance of work for which a permit is granted whether or not the said liability arises as a result of the negligence of the person firm, or corporation to whom the permit was issued.

SECTION 4. Penalties and Remedies for Violations:

- (a) Any person, firm, or corporation violating the provisions of this Ordinance shall pay a fine of up to One Thousand (\$1,000.00) Dollars and costs, to be recovered in the Borough's name before a District Justice. In default of payment, the person shall be imprisoned for a period of not more than thirty (30) days.
- (b) The Borough may revoke any permit issued to any person, firm, or corporation violating the provisions of this Ordinance.
- (c) The imposition of penalties shall not preclude the Borough from instituting an appropriate action or proceeding to prevent the performance of work or act violating this Ordinance, or to restrain, correct, abate a violation, or seek relief by a complaint in equity.
- (d) All written notices shall be served upon the property's owner, if the owner is a Borough resident. If the property owner is not a resident, then the notice may be served upon the agent or tenant of the property's owner, or upon the property's occupant. Notice shall be sent by certified mail or by special messenger to the last known address of the individuals, association or corporation in whose name the title to the lot, parcel, tract of land or premises appears of public record to be owned, and if such certified mail be returned unclaimed or special messenger be unable to find the owner, or if the owner has no agent or tenant or there is no occupier of the premises, then such notice shall be given by posting a copy of the same on the land or premises so involved.

SECTION 5. Repeal of Ordinances:

All ordinances or parts of ordinances inconsistent with this Ordinance are hereby repealed insofar as they apply to permits issued or acts or violations occurring before this Ordinance's effective date. Any other ordinances or parts of ordinances conflicting with the provisions of this Ordinance are hereby repealed insofar as they are inconsistent with this Ordinance's provisions.

ENACTED AND ORDAINED this 14th day of April, 2010.

/s/ [Signature]
President of Council

Attest: /s/ Sherry M Edwards
Secretary of Council

(BOROUGH SEAL)



Approved: /s/ Austin Scandiber
Mayor

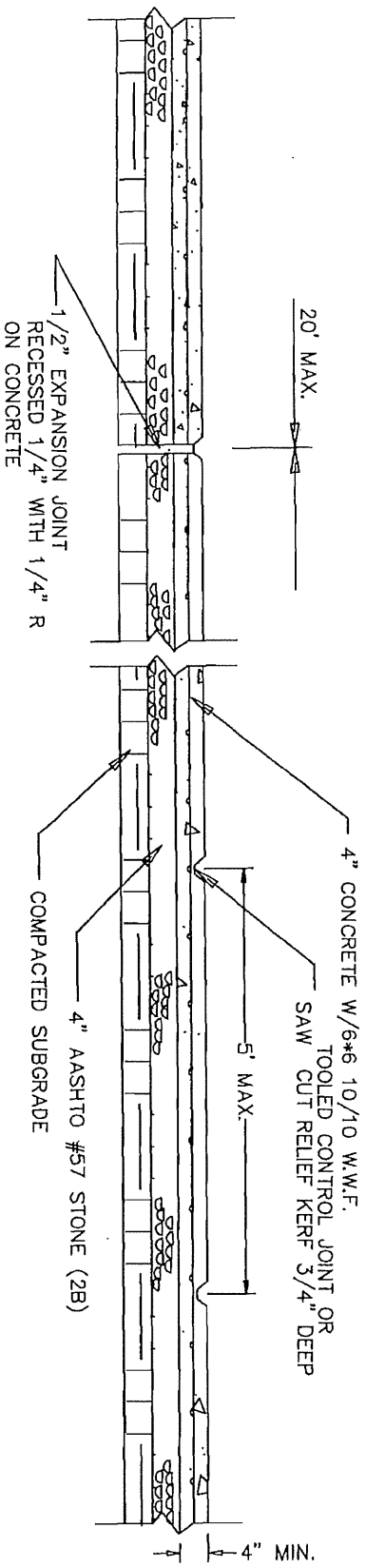

BOROUGH OF ORWIGSBURG – STANDARD DETAIL
 CONCRETE SIDEWALK

NOTES:

- A NONSLIP FINISH SHALL BE PROVIDED ON ALL SIDEWALKS.
- ALL CONCRETE SHALL BE AIR ENTRAINED AND HAVE A MINIMUM COMPRESSIVE STRENGTH OF 3,500 PSI
- ALL NEW SIDEWALKS SHALL BE A MINIMUM OF 5' WIDE.
- SIDEWALKS SHALL HAVE A MINIMUM 2% CROSSSLOPE TO PROVIDE POSITIVE DRAINAGE TO THE CURB/GUTTER LINE

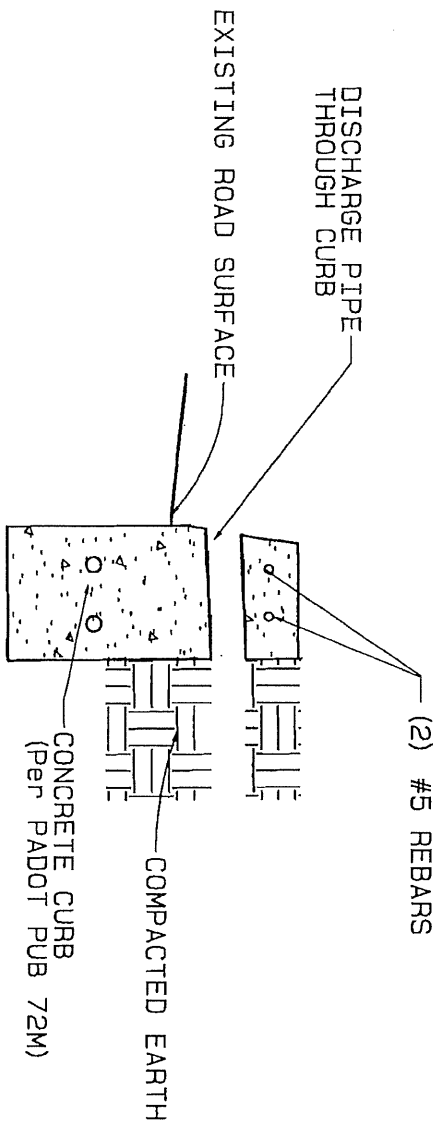

BOROUGH OF ORWIGSBURG - STANDARD DETAIL
 ROOF DRAIN EXITING THROUGH CURBING (N.T.S.)

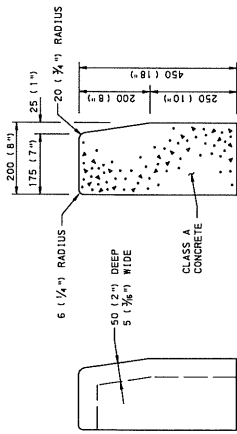

DETAIL A
CONTRACTION JOINT

TYPICAL
CROSS SECTION

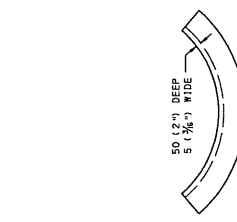

DETAIL B
CONTRACTION JOINT

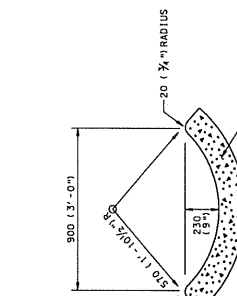

TYPICAL
CROSS SECTION

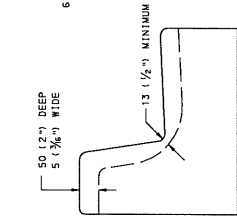

DETAIL C
CONTRACTION JOINT

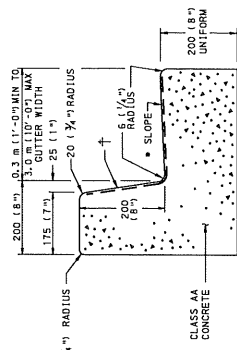

TYPICAL
CROSS SECTION

* UNDER 1.5 m (5'-0") GUTTER WIDTH =
 1.5 m (5'-0") AND GREATER GUTTER WIDTH =
 4.02 (13'-2") MIN.
 NOTE: REFER TO RC-67M FOR MAXIMUM SLOPE OF
 GUTTER WHEN PLACED AT A CURB RAMP
 † REPRESENTS WIDTH OF GUTTER FOR
 COMPUTING PAY AREA

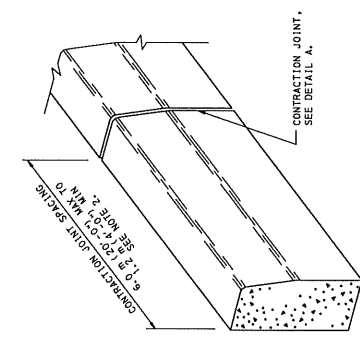

PLAIN CEMENT CONCRETE CURB

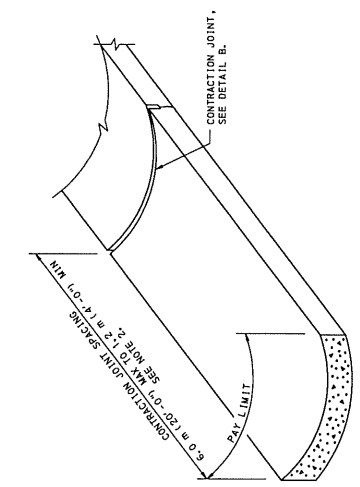

PLAIN CEMENT CONCRETE CURB

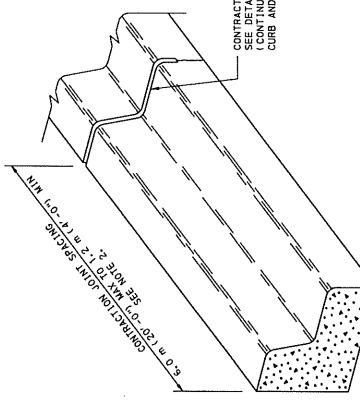

PLAIN CEMENT CONCRETE CURB GUTTER

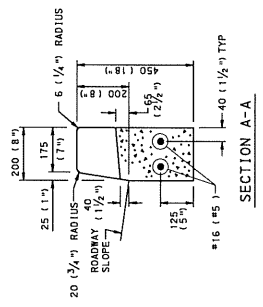

SECTION A-A

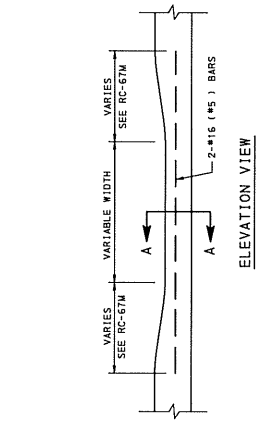

ELEVATION VIEW

DEPRESSED CURB FOR DRIVEWAYS

- NOTES
1. PROVIDE MATERIALS AND CONSTRUCTION MEETING THE REQUIREMENTS FOR PLAIN CEMENT CONCRETE CURB AND GUTTER. REFER TO SECTION 640 FOR PLAIN CEMENT CONCRETE CURB AND GUTTER. REFER TO SECTION 641 FOR PLAIN CEMENT CONCRETE CURB GUTTER.
 2. SEAL CONTRACTION JOINTS IN UNIFORM LENGTHS OR AS SHOWN.
 3. PLACE 20 (3/4") THICK PREMOULD EXPANSION JOINT FILLER MATERIAL AT STRUCTURES AND AT THE END OF CURBS. THE FILLER SHALL BE ADJACENT TO CURB OR TO CONCRETE TO CROSS SECTIONAL AREA OF CURB.
 4. SEE RC-50M FOR PLAIN CEMENT CONCRETE CURB SLOPED TOP TREATMENT AT END OF STRUCTURES.
 5. WHERE CURBS ARE INSTALLED ADJACENT TO PARKING LANES, A 150 (6") WIDE CURB SHALL BE UTILIZED WITH APPROVAL FROM THE LOCAL MUNICIPALITY.
 6. ALL DIMENSIONS ARE IN MILLIMETERS UNLESS OTHERWISE NOTED. U.S. CUSTOMARY UNITS IN () PARENTHESES.

COMMONWEALTH OF PENNSYLVANIA
 DEPARTMENT OF TRANSPORTATION
 BUREAU OF DESIGN

CURBS AND GUTTERS